

**Non-Reinforced Concrete Pipe
O-Ring Joint
12" - 36" Diameter**

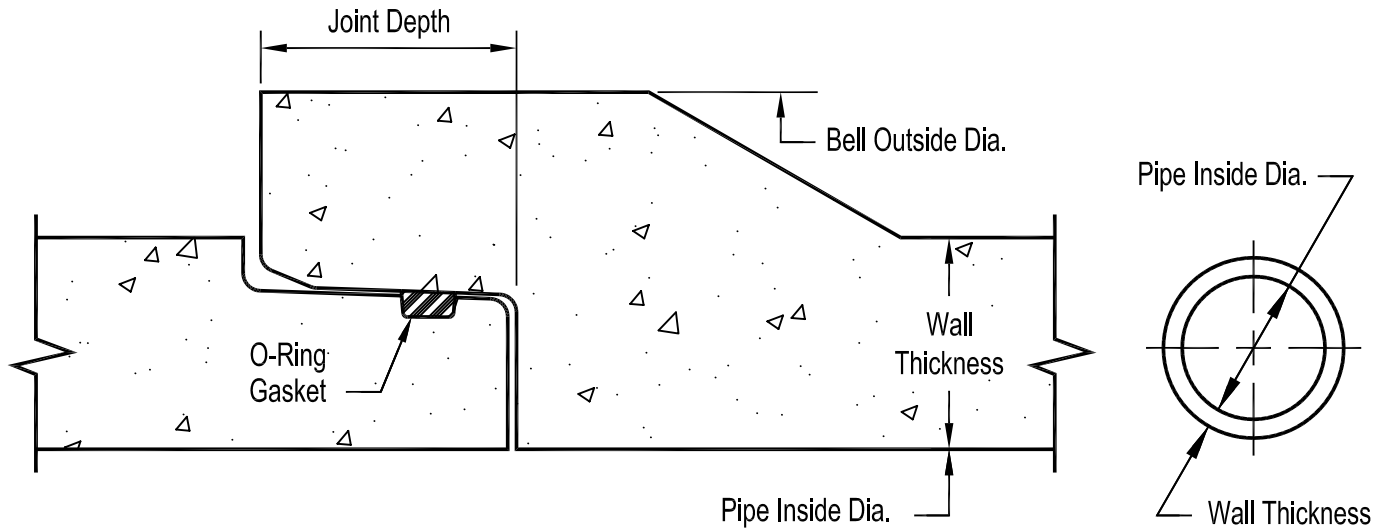

Section Thru Joint

Section Thru Barrel

Table of Dimensions and Weights					
Pipe Inside Diameter (Inches)	Wall Thickness (Inches)	Joint Depth (Inches)	Bell Outside Diameter (Inches)	Length (Feet)	Weight (Lbs./Ft.)
12	3	4 5/8	23	6	120
15	3	4 5/8	26	6, 8	155
18	3	4 5/8	29	6, 8	175
21	3	4 5/8	32	6, 8	225
24	3	4 5/8	35	6, 8	290
27	3 1/4	4 5/8	3 3/4	6, 8	350
30	3 1/2	4 5/8	42 1/4	6, 8	410

Pipe dimensions may vary depending upon equipment availability.

Notes:

1. Pipe manufactured to meet current ASTM specifications.
2. Contact a Concrete Pipe Division representative for details not listed on this sheet.